

IS : 2470 (Part 2) - 1985

Indian Standard

CODE OF PRACTICE FOR
INSTALLATION OF SEPTIC TANKS

**PART 2 SECONDARY TREATMENT AND DISPOSAL
OF SEPTIC TANK EFFLUENT**

(*Second Revision*)

First Reprint APRIL 1990

UDC 628.352 : 006.76

© Copyright 1985

BUREAU OF INDIAN STANDARDS
MANAK BHAVAN, 9 BAHADUR SHAH ZAFAR MARG
NEW DELHI 110002

*Indian Standard*CODE OF PRACTICE FOR
INSTALLATION OF SEPTIC TANKSPART 2 SECONDARY TREATMENT AND DISPOSAL
OF SEPTIC TANK EFFLUENT*(Second Revision)*

Water Supply and Sanitation Sectional Committee, BDC 24

Chairman

SHRI J. D' CRUZ

*Representing*Water Supply & Sewage Disposal Undertaking,
New Delhi*Members*CHIEF ENGINEER (CIVIL I) (*Alternate to*

Shri J. D' Cruz)

ADVISER (PHE)

Ministry of Works and Housing

DEPUTY ADVISER (PHE) (*Alternate*)

SHRI M. S. ASNANI

Public Works Department, Delhi Administration,
New DelhiSHRI P. C. SRIVASTAVA (*Alternate*)

SHRI N. S. BHAIKAVAN

Public Health Engineering Department, Govern-
ment of Kerala, TrivandrumSUPERINTENDING ENGINEER (*Alternate*)

SHRI I. CHANDRA

Public Works Department (Public Health
Branch) Government of Haryana,
ChandigarhSHRI K. K. GANDHI (*Alternate*)

CHIEF ENGINEER (CONSTRUCTION)

Uttar Pradesh Jal Nigam, Lucknow

SUPERINTENDING ENGINEER (*Alternate*)

SHRI R. C. P. CHAUDHARY

Engineers India Ltd, New Delhi

SHRI H. V. RAO (*Alternate*)

SHRI S. K. DASGUPTA

Calcutta Metropolitan Development Authority,
CalcuttaSHRI S. R. MUKHERJEE (*Alternate*)

PROF J. M. DAVE

Institution of Engineers (India), Calcutta

SHRI S. G. DEOLALIKAR

In personal capacity (Flat No. 403, Savitri Cinema
Commercial Complex, Greater Kailash II, New
Delhi)*(Continued on page 2)*

© Copyright 1985

BUREAU OF INDIAN STANDARDS

This publication is protected under the *Indian Copyright Act* (XIV of 1957) and reproduction in whole or in part by any means except with written permission of the publisher shall be deemed to be an infringement of copyright under the said Act.

IS : 2470 (Part 2) - 1985

(Continued from page 1)

<i>Members</i>	<i>Representing</i>
HYDRAULIC ENGINEER	Municipal Corporation of Greater Bombay, Bombay
CHIEF ENGINEER (SEWERAGE PROJECTS) (<i>Alternate</i>)	
SHRI R. A. KHANNA	Public Health Engineering Department, Government of Madhya Pradesh, Bhopal
SHRI D. K. MITRA (<i>Alternate I</i>)	
SHRI I. S. BAWEJA (<i>Alternate II</i>)	
SHRI P. KRISHANAN	Central Public Works Department, New Delhi
SURVEYOR OF WORKS-1(NDZ) (<i>Alternate</i>)	
SHRI S. R. KSHIRSAGAR	National Environmental Engineering Research Institute (CSIR), Nagpur
DR P.V.R.C. PANICKER (<i>Alternate</i>)	
SHRI M. Y. MADAN	The Hindustan Construction Co Ltd, Bombay
SHRI C. E. S. RAO (<i>Alternate</i>)	
SHRI S. L. MAINI	Punjab Public Works Department (Public Health Branch), Government of Punjab, Patiala
MANAGING DIRECTOR	Punjab Water Supply & Sewerage Board, Chandigarh
SHRI R. NATARAJAN	Hindustan Dorr-Oliver Ltd, Bombay
SHRI SUBHASH VERMA (<i>Alternate</i>)	
SHRI K. J. NATH	All India Institute of Hygiene & Public Health, Calcutta
SHRI D. GUIN (<i>Alternate</i>)	
SHRI A. PONNAMBALAM	Tamil Nadu Water Supply & Drainage Board, Madras
SHRI RANJIT SINGH	Ministry of Railways
DR A. V. R. RAO	National Buildings Organization, New Delhi
SHRI O. P. RATRA (<i>Alternate</i>)	
PROF Y. N. RAMACHANDRA RAO	Engineer-in-Chief's Branch (Ministry of Defence), New Delhi
MAJ B. S. PARMAR (<i>Alternate</i>)	
SECRETARY	Indian Water Works Association, Bombay
SECRETARY GENERAL	Institution of Public Health Engineers India, Calcutta
SHRI R. N. BANERJEE (<i>Alternate</i>)	
SHRI L. R. SEHGAL	L. R. Sehgal & Co, New Delhi
SHRI S. K. SHARMA	Central Building Research Institute (CSIR), Roorkee
SHRI B. N. THYAGARAJA	Bangalore Water Supply & Sewerage Board, Bangalore
SHRI H. S. PUTTAKEMPANNA (<i>Alternate</i>)	
SHRI V. VARADARAJAN	Madras Metropolitan Water Supply & Sewerage Board, Madras
SHRI S. DAIVAMANI (<i>Alternate</i>)	
SHRI G. RAMAN, Director (Civ Engg)	Director General, ISI (<i>Ex-officio Member</i>)

Secretary

SHRI A. K. AVASTHY
Assistant Director (Civ Engg), ISI

(Continued on page 21)

*Indian Standard***CODE OF PRACTICE FOR
INSTALLATION OF SEPTIC TANKS****PART 2 SECONDARY TREATMENT AND DISPOSAL
OF SEPTIC TANK EFFLUENT***(Second Revision)***0. FOREWORD**

0.1 This Indian Standard (Part 2) (Second Revision) was adopted by the Indian Standards Institution on 28 February 1985, after the draft finalized by the Water Supply and Sanitation Sectional Committee had been approved by the Civil Engineering Division Council.

0.2 In a septic tank, even if of adequate design and capacity, only a portion of the suspended solids settle in the tank, the dissolved organic matter and some of the suspended matter are discharged from the tank in the effluent and will cause a health hazard if the effluent is not adequately disposed of.

0.3 The title of the code which was originally 'Code of practice for design and construction of septic tank: Part 1 Small installations, and Part 2 Large installations', have also been amended to read 'Code of practice for installation of septic tanks: Part 2 Secondary treatment and disposal of septic tank effluent'.

0.4 This standard covers the recommended practice for the disposal of effluent from septic tanks only. The design and construction of small as well as large septic tanks (up to 300 persons) have been covered in IS : 2470 (Part 1) 'Code of practice for installation of septic tank: Part 1 Design criteria and construction'.

0.5 Disposal of effluent from septic tank was originally given in IS : 2470 (Part 1)-1968 'Code of practice for design and construction of septic tanks: Part 1 Small installations (first revision)'. In this revision, the disposal of septic tank effluent by biological filter have been covered in details. Upflow anaerobic filters for the disposal of effluent from the septic tank, which are preferred in rocky areas, are also covered in detail.

0.6 For the purpose of deciding whether a particular requirement of this standard is complied with, the final value, observed or calculated, expressing the result of a test, shall be rounded off in accordance with IS : 2-1960*. The number of significant places retained in the rounded off value should be the same as that of the specified value in this standard.

0.7 This Code of practice represents a standard of good practice and therefore takes the form of recommendation.

1. SCOPE

1.1 This code lays down recommendations for the methods of treatment and disposal of effluent from septic tanks.

2. TERMINOLOGY

2.0 For the purpose of this standard, the following definitions shall apply.

2.1 **Biological Filter** — It consists of a bed of gravel, broken stone, clinkers or such other material through which sewage flows. The organic matter present in the sewage gets partly removed and stabilised by the biological slime on the surface of the media.

2.2 **Dispersion Trench** — A trench in which open jointed pipes are laid and surrounded by coarse aggregate media and overlaid by fine aggregate. The effluent gets dispersed through the open joints and is absorbed in the neighbouring soil.

2.3 Effluents

a) **Tank Effluent** — The supernatant liquid discharge from a septic tank.

b) **Filter Effluent** — The liquid discharged from a biological filter.

2.4 **Filter Media** — Materials, such as clinker, broken stone and gravel through which sewage flows and on the surface of which zoological films develop.

2.5 **Seepage Pit (Soakaway, Soak Pit)** — A pit through which effluent is allowed to seep or leach into the surrounding soil.

2.6 **Sewage** — The liquid waste of a household or community including human excreta.

*Rules for rounding off numerical values (revised).

2.7 Subsoil Water — Water occurring naturally below the surface of the ground.

2.8 Surface Water — The run-off from precipitation and other water that flows over surface of the ground.

3. PRELIMINARY DATA FOR DESIGN

3.1 In order to design secondary treatment works of the treatment of effluent from septic tanks, information on the following items should be collected.

{a} Nature of soil and subsoil condition

- 1) The fullest possible information on the nature of the soil and subsoil conditions should be obtained, as well as the approximate water table and any available records of flood levels or information as to the variation, seasonal or otherwise, in the water table.
- 2) The soil should be explored to a sufficient depth to ascertain the soils horizons and the soil types, grading, structure and permeability. The external drainage factors, such as slope of ground and position of surface water drains, if any, should be ascertained. Exploration of the soil to a significant depth should be made because casual or visual inspection may fail to reveal unsuitable conditions, such as an impervious granite layer under sand, or on the other hand suitable conditions, such as permeable schist overlaid by clay.
- 3) *Soil Types* — An approximate field identification of the soils should be made in accordance with the methods given in IS : 1498-1970*. Trial bores or boreholes should be sunk along the line of the proposed filter and data there from tabulated. In general, the information obtained from trial bores is more reliable than that from boreholes. The positions of trial bores or boreholes should be shown on the plans together with sections showing the strata found and the dates on which the water levels were recorded. Full information should be given as to the structure, type, colour, permeability, depth and horizons of the soil, as well as any impedances to drainage such as rock bars.

*Classification and identification of soils for general engineering purpose (*first revision*).

4) *Percolation Test* — To decide on the details of a soil absorption system a soil absorption test as given in Appendix A shall be conducted. The percolation rate, that is time required in minutes for water to fall 25 mm in the test-hole shall be determined. A test in trial pits at more than one place in the area should be undertaken to permit deriving an average figure for percolation rate.

b) Site plan showing the proposed or existing buildings as well as reduced ground levels over the site.

c) Discharge from the septic tank.

d) The position and nature of outfall ditches, wells, tanks or small streams in the vicinity, if any.

3.2 When assessing the feasibility of a proposed effluent disposal scheme involving absorption of effluent in soil, consideration should be given to factors such as:

a) The area of land available for the absorption.

b) The risk of prejudicing adjoining property, underground water supplies, swimming and wading pools and the like, by seepage from the area.

c) The permeability and depth of the soil on the proposed site for the absorption area. Percolation tests are useful but the season of the year when the tests are made and many other factors have to be taken into account when assessing the results of the tests. Long-term efficiency of an absorption area can be adversely affected by high concentrations of chlorides and sulphides in the soil.

d) Any seasonal changes in ground water level and absorptive capacity of the site.

e) The climate and its effect on the evaporation from the site, for example, distribution of rainfall, hours of sunshine, prevalence of wind.

f) The effect of seepage and surface water from surrounding areas at higher levels than the proposed absorption area.

3.3 Before any work is started, the approval from the Administrative Authority should be obtained.

4. METHODS OF TREATMENT AND DISPOSAL OF EFFLUENT

4.1 The following methods of disposal are described in this Code:

- a) Soil absorption system,
- b) Biological filters, and
- c) Upflow anaerobic filters

4.2 Depending on the position of the subsoil water level, soil and subsoil conditions, the recommended method of disposal of the effluent is given in Table 1.

TABLE 1 RECOMMENDED METHOD OF DISPOSAL FOR SEPTIC TANK EFFLUENT

(Clauses 4.2, 6.0 and 7.0)

POSITION OF THE SUBSOIL WATER LEVEL FROM GROUND LEVEL	SOIL AND SUBSOIL CONDITION		
	Porous Soil with Percolation Rate		Dense and clays soil with percolation rate exceeding 60 min
	Not exceeding 30 min	Exceeding 30 min but not exceed- ing 60 min	
Within 1·8 m	Dispersion trench located partly or fully above ground level in a mound	Dispersion trench located partly or fully above ground level in a mound	Biological filter partly or fully above ground level with under-drains or upflow anaerobic filter and the effluent led into a surface drain or used for gardening
Below 1·8 m	Seepage pit or dispersion trench	Dispersion trench	Subsurface biological filter with under- drains or upflow anaerobic filter and the effluent led into a drain or used for gardening

NOTE— Where the above mentioned methods are not feasible and where the effluent has to be discharged into open drain it should be disinfected.

5. SOIL ABSORPTION SYSTEMS

5.1 Design of Soil Absorption Systems— The allowable rate of application of effluent per unit area of dispersion trench or seepage pit is limited by the percolation rate of the soil (determined in accordance

IS : 2470 (Part 2) - 1985

with Appendix A) and the values obtainable from the graph given in Fig. 1 may be used for guidance; the allowable rate of effluent application for certain selected values of percolation rates are given in Table 2.

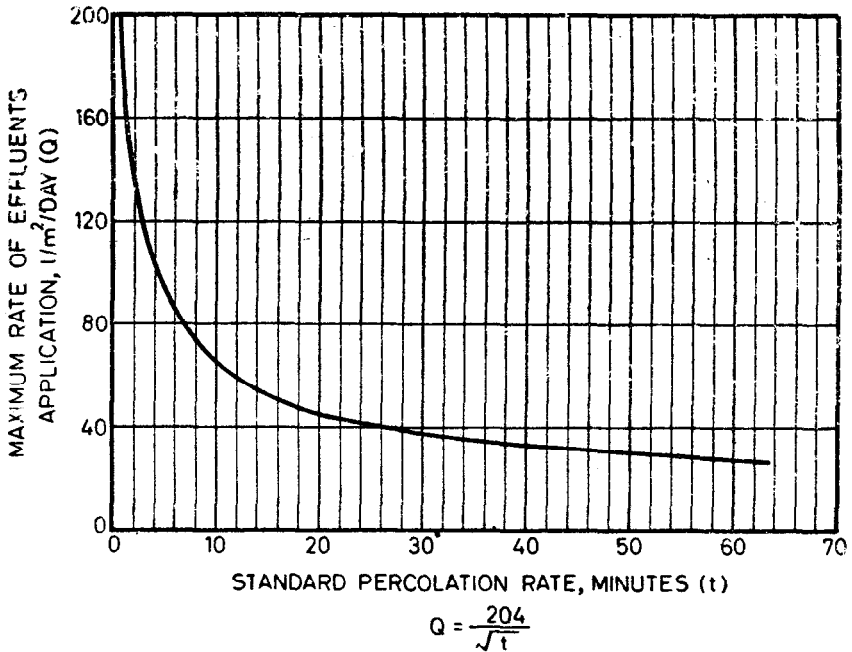

FIG. 1 ALLOWABLE RATE OF EFFLUENT APPLICATION FOR STANDARD PERCOLATION RATE

5.2 Construction of the Soil Absorption System — Two types of soil absorption system have been covered:

- a) Seepage pit, and
- b) Dispersion trench.

5.2.1 Seepage Pit — The seepage pit may be of any suitable shape with the least cross-sectional dimension of 0.90 m and not less than 1.0 m in depth below the invert level of the inlet pipe. The pit may be lined with stone, brick or concrete blocks with dry open joints which should be backed with at least 75 mm of clean coarse aggregate (see Fig. 2A). The lining above the inlet level should be finished with mortar. In the case of pits of large dimensions, the top portion may be narrowed to

reduce the size of the RCC cover slabs. Where no lining is used, specially near trees, the entire pit should be filled with loose stones. A masonry ring may be constructed at the top of the pit to prevent damage by flooding of the pit by surface run-off (see Fig. 2B). The inlet pipe may be taken down to a depth of 0.90 m from the top as an anti-mosquito measure. Illustrations of typical constructions of seepage pit are given in Fig. 2

TABLE 2 ALLOWABLE RATE OF EFFLUENT APPLICATIONS TO SOIL ABSORPTION SYSTEM

(Clause 5.1)

PERCOLATION RATE Min	MAXIMUM RATE OF EFFLUENT APPLICATION l/m ² /day
1 or less	204
2	143
3	118
4	102
5	90
10	65
15	52
30	37
45	33
60	26

NOTE 1 — The absorption area for a dispersion trench is the trench bottom area.

NOTE 2 — The absorption area for seepage pits is the effective side wall area, effective depth being measured from 150 mm below invert level of inlet pipe to the bottom of the pit (see Fig. 2).

NOTE 3 — If the percolation rate exceeds 30 minutes, the soil is unsuitable for soakaways. If the percolation rate exceeds 60 minutes, the soil is unsuitable for any soil absorption system.

5.2.2 Dispersion Trench — Dispersion trenches shall be 0.5 to 1.0 m deep and 0.3 to 1.0 m wide excavated to a slight gradient and shall be provided with 150 to 250 mm of washed gravel or crushed stones. Open jointed pipes placed inside the trench shall be made of unglazed earthen-ware clay or concrete and shall have minimum internal diameter of 75 to 100 mm. Each dispersion trench should not be longer than 30 m and trenches should not be placed closer than 2.0 m.

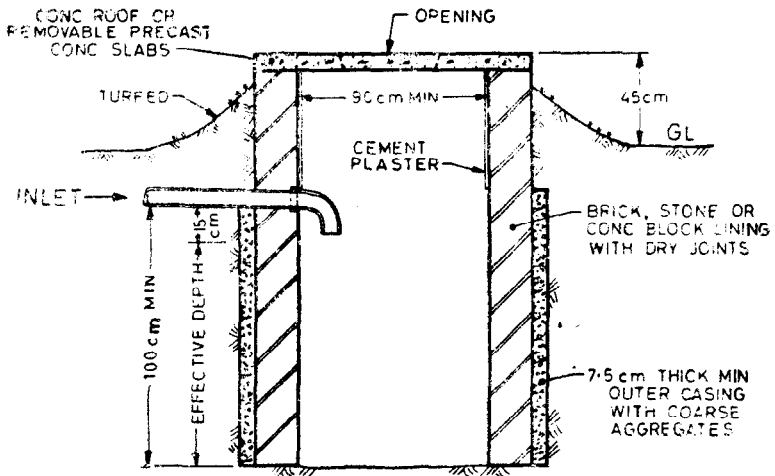

2A EMPTY PIT WITH LINING

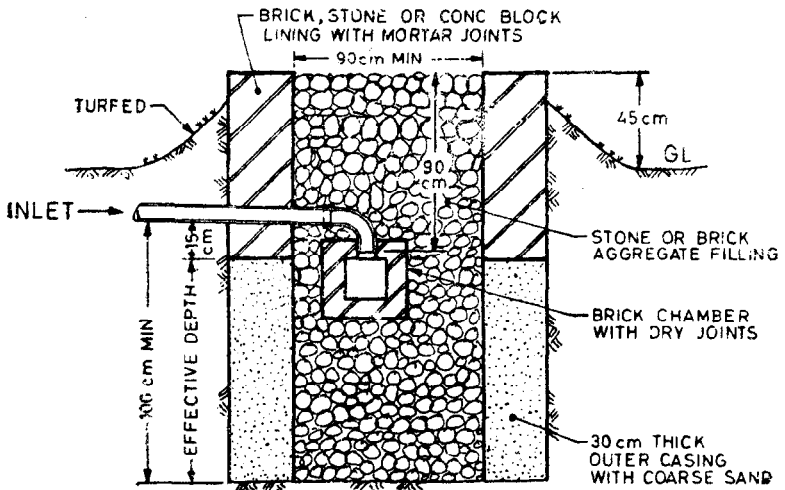

2B PIT WITH FILLING WITHOUT LINING

FIG. 2 TYPICAL ILLUSTRATIONS OF SEEPAGE PITS

5.2.2.1 The covering for the pipes on the top should be with coarse aggregate of uniform size to a depth of approximately 150 mm. The aggregate above this level may be graded with aggregate 12 to 15 mm to prevent ingress of top soil while the free flow of water is in a way retarded. The trench may be covered with about 300 mm of ordinary soil to form a mound and turfed over. Dispersion trenches are not recommended in areas where fibrous roots of trees or vegetation are likely to penetrate the system and cause blockages. The finished top surface may be kept at least 150 mm above ground level to prevent direct flooding of the trench during rains. Illustration of a typical soil absorption system through dispersion trenches is given in Fig. 3.

5.3 Location of Subsurface Absorption System — A subsoil dispersion system shall not be closer than 18 m from any source of drinking water, such as well, to mitigate the possibility of bacterial pollution of water supply. It shall also be as far removed from the nearest habitable building as economically feasible but not closer than 6 m, to avoid damage to the structures. The actual distance, however, shall be based on the soil conditions in relation to both percolation and bearing capacity. Care should be taken that the ground below the adjacent building is not likely to be affected by the effluent seeping into the soil. In lime stones or crevice rock formations, the soil absorption system is not recommended as there may be channels in the formation which may carry contamination over a long distance, in such case, and generally where suitable conditions do not exist for adoption of soil absorption systems, the effluent, where feasible should be treated in a biological filter or upflow anaerobic filters.

5.3.1 It is an advantage if the area available for disposal of effluent is large enough to permit relocation of absorption trenches when replacement of trenches become necessary.

6. BIOLOGICAL FILTERS

6.0 Biological filters are suitable for treatment of septic tank effluent where the soil is relatively impervious (*see* Table 1), water logged areas or where limited land area is available. In a biological filter, the effluent from septic tank is brought into contact with a suitable medium, the surfaces of which become coated with an organic film. The film assimilates and oxidizes much of the polluting matter through the agency of micro-organisms. The biological filter requires ample ventilation and an efficient system of underdrains leading to an outlet.

6.1 Construction — The depth of medium should be 1 400 mm but never less than 900 mm. The medium should be retained in position by walls of adequate trench. The filter should have a concrete floor,

laid to falls with a system of underdrains laid on it and consisting of field drains half channels laid upside down and open jointed, or special tiles discharging to the outlet.

6.2 Distribution — The septic-tank effluent should be distributed evenly over the surface of the biological filter through which it percolates to the floor. Biological filters may be either rectangular (*see* Fig. 4A) or circular (*see* Fig. 4B) in shape and a series of fixed channels or rotating arm distributor may be used for distributing effluent on the medium.

6.3 Filter Media — The filter sand and gravel shall conform to IS : 8419 (Part 1)-1977*.

6.4 Ventilation — Adequate ventilation of biological filter is essential. Air vents communicating with the floor level of the filter should be provided. Where the filter is below ground level, the vent pipes from the ends of the underdrains should be carried to 150 mm above ground level outside the filter. Normally the filter should not be covered, but wire netting may be used to prevent falling of leaves fouling the surface of the filter or blocking the ends of the vent pipe.

6.5 Volume of Filter — It is essential that the volume of filter medium provided is sufficient to allow for sewage flow which occurs with small installations, such variation being more pronounced in the smaller number of persons are served. For populations of up to 10 persons the volume should be 1 m³ of medium per head, of resident population for over 10 and up to 50 persons, 0.8 m³ and for over 50 and up to 300 persons, 0.6 m³.

If pumping of the septic tank effluent forms part of scheme, recirculation of final effluent to dilute the septic tank effluent may be introduced to reduce the volume of the filter.

6.6 Treatment of Filter Effluent — The filter effluent is either discharged into surface drain or evenly distributed over a grass plot from the system of channels. Where the effluent is likely to contaminate the watercourse, the effluent should be adequately disinfected.

7. UPFLOW ANAEROBIC FILTER

7.0 Upflow type of filters (reverse filter) operating under submerged conditions is a method for disposal of septic tank effluents in areas where dense soil condition (*see* Table 1), high water table and limited availability of open land are factors to be considered for successful

*Requirements for filtration equipment : Part 1 Filtration media sand and gravel.

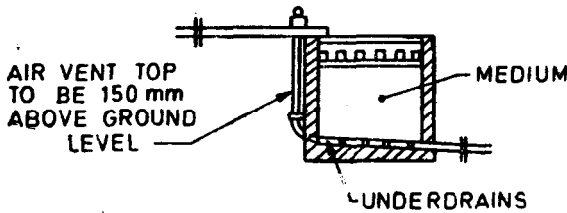
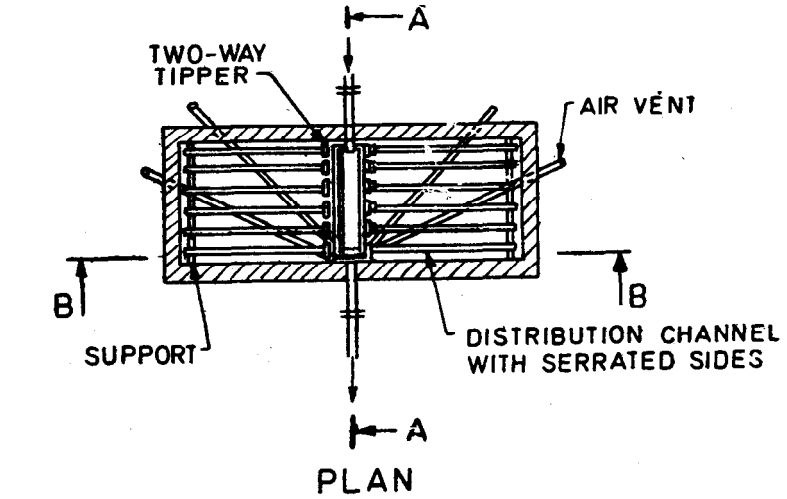

SECTION A A

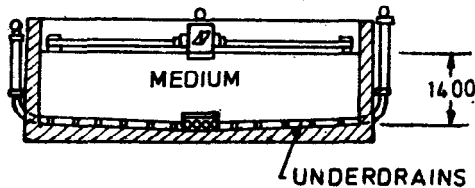

SECTION B B

All dimensions in millimetres.

NOTE — Flexible joints may be required on inlet or outlet connections, where rigid pipes are used.

FIG. 4A RECTANGULAR BIOLOGICAL FILTER

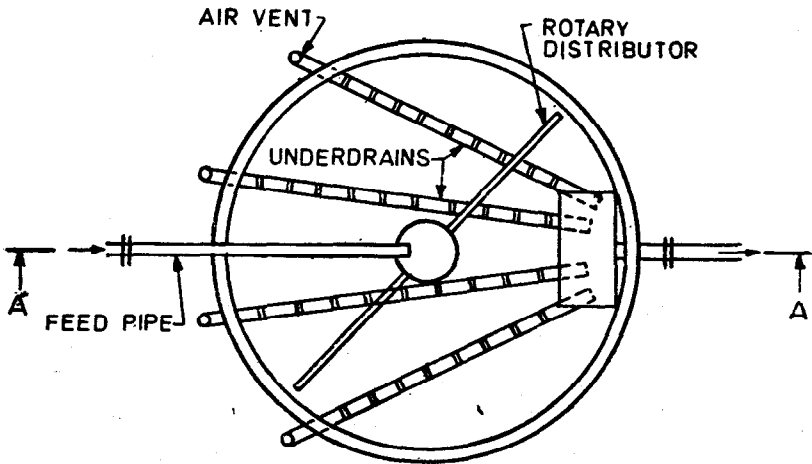

PLAN

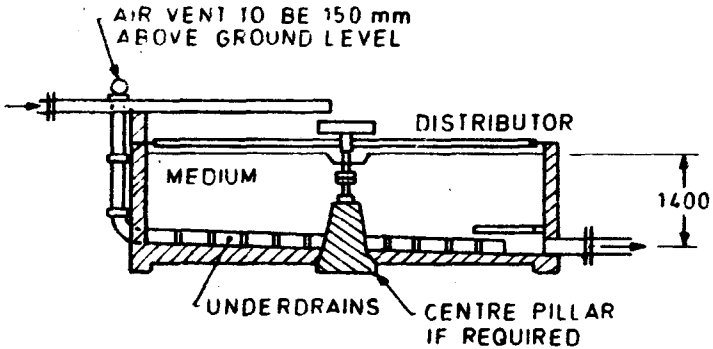

SECTION AA

All dimensions in millimetres.

NOTE — Flexible joints may be required on inlet or outlet connections, where rigid pipes are used.

FIG. 4B CIRCULAR BIOLOGICAL FILTER

disposal of effluents by secondary treatment. The septic tank effluent is introduced from the bottom and the microbial growth is retained on the stone media making possible higher loading rates and efficient digestion. The capacity of the unit is 0.04 to 0.05 m³ per capita or 1/3 to 1/2 the liquid capacity of the septic tank it serves. BOD removals of 70 percent can be expected and the effluent is clear and free from odour and nuisance. The flow sheets of the filter system are shown in Fig. 5.

7.1 Types — Upflow anaerobic filters are of the following types:

- a) Single chambered rectangular type,
- b) Double chambered rectangular type, and
- c) Circular type.

7.2 Construction Features — In an upflow filter, the tank effluent enters at the bottom through a system of underdrains, flows upwards through a layer of coarse material generally 0.6 to 1.2 m deep and is discharged over a weir or trough at the top. The driving head in the filter, that is, the difference between the water level and the filter may be as low as 25 to 150 mm during normal functioning.

7.2.1 Single Chambered Rectangular Type — In this type (Fig. 6) an upflow filter with a rectangular chamber is constructed to treat the effluent from a normal domestic septic tank. The chamber is packed with coarse material and the size of the packing media should be 20 mm. The medium rests on a perforated concrete false bottom slab. The effluent from septic tank enters the bottom of the filter chamber through a 150 mm pipe and is distributed upward through the media from a perforated slab at the bottom.

The vertical inlet is fitted with a tee at the bottom, one branch of which leads to the filter and the other branch is kept plugged while the filter functions. The plug can be removed to facilitate emptying into an adjoining chamber and cleaning the filter where required. The effluent from the top of the bed is allowed to escape over a V-notch. The sill level is kept 150 mm above the top of the medium.

7.2.2 Double Chambered Rectangular Type — The filter consists of two interconnected compartments (Fig. 7). The first chamber is filled to a depth of 0.55 m with 20 mm coarse medium. The second chamber is filled to a depth of 0.45 m with 20 mm size coarse aggregate. The septic tank effluent falls through a perforated tray over the medium in the first compartment and enters the second compartment directly from the bottom. The effluent passes up through the medium in the second chamber and escapes over a V-notch placed 75 mm above the top of the



(1)

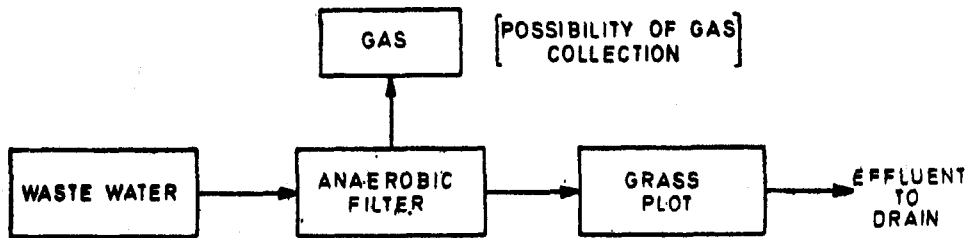

(2)

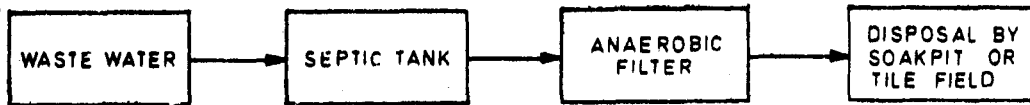

(3)

FIG. 5 ANAEROBIC FILTER SYSTEM

medium. By this arrangement, the time of travel of the effluent through the filter is lengthened. The two chambers are each fitted at the bottom with a 75 mm galvanized iron pipe leading to an adjacent chamber. A valve in these pipes allows the filters to be partly desludged into the collecting chamber.

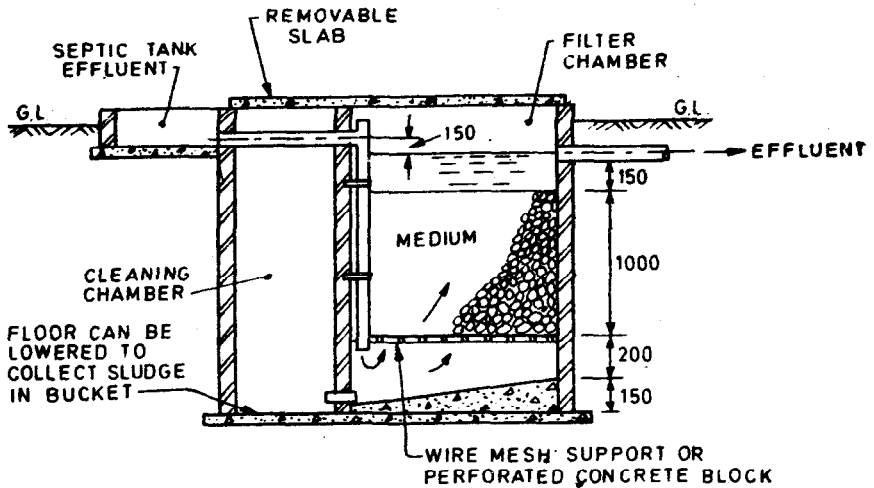

FIG. 6 UPFLOW ANAEROBIC FILTER (SINGLE CHAMBERED RECTANGULAR TYPE)

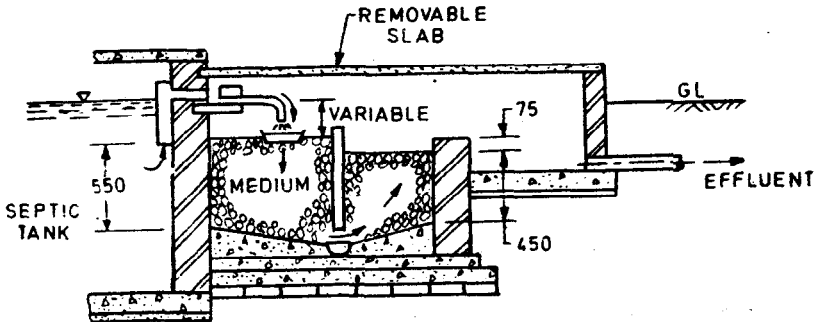

FIG. 7 UPFLOW ANAEROBIC FILTER (DOUBLE CHAMBERED RECTANGULAR TYPE)

7.2.3 Circular Filter — A circular filter 0.9 m in dia may also be constructed. Medium of aggregate of uniform size 20 mm should be

packed to rest on a perforated concrete slab. The effluent may be made to escape over the top of the medium through equally placed notches along the periphery of the filter. The sill level is usually 100 mm above the top of the medium.

7.3 Filter Media — The filter media shall conform to IS:8419 (Part 1)-1977*.

7.4 Treatment of Filter Effluent — The filter effluent shall be treated as given in 6.6.

A P P E N D I X A

(Clause 5.1)

DETERMINATION OF THE SOIL ABSORPTION CAPACITY

A-1. PERCOLATION TEST

A-1.1 Percolation test should be conducted as described in A-1.2 to A-1.6 to determine the permeability of the soil at any depth at which it is intended to dispose of the effluent.

A-1.2 A square or a circular hole with side width or diameter respectively 100 to 300 mm and vertical sides shall be dugged or bored to the depth of the proposed absorption trench. The bottom and sides of the holes shall be carefully scratched in order to remove any smeared soil surface and to provide a natural soil interface into which water may percolate. All the loose material shall be removed from the hole and coarse sand or fine gravel shall be added for a depth of about 50 mm, to protect the bottom from scouring and sediment.

A-1.3 Water shall then be poured up to a minimum depth of 300 mm over the gravel. In order to ensure that the soil is given ample opportunity to swell and to approach the condition it will be in, during the wettest season of the year, the percolation shall be determined 24 hours after the water is added. If the water remains in the test hole after the overnight swelling period, the depth shall be adjusted to 150 mm over the gravel. Then from fixed reference point the drop in water level shall be noted over a 30 minute period. This drop shall be used to calculate the percolation rate.

*Requirements for filtration equipment: Part 1 Filtration media—Sand and gravel.

A-1.4 If no water remains in the hole, water shall be added to bring the depth of the water in the hole till it is 150 mm over the gravel. From a fixed reference point, the drop in water level shall be measured at 30 minutes intervals for 4 hours, re-filling 150 mm over the gravel as necessary. The drop that occurs during the final 30 minutes period shall be used to calculate the percolation rate. The drops during prior periods provide information for possible modification of the procedure to suit local circumstances.

A-1.5 In sandy soils or other porous soils in which the first 150 mm of water seeps away in less than 30 minutes after the overnight swelling period, the time interval between measurement shall be taken as 10 minutes and the test run for one hour. The drop that occurs during the final 10 minutes shall be used to calculate the percolation rate.

A-1.6 Percolation Rate—Based on the final drop, the percolation rate, that is, the time in minutes required for water to fall 25 mm, shall be calculated.

(Continued from page 2)

Water Supply and Plumbing Subcommittee, BDC 24 : 1

<i>Members</i>	<i>Representing</i>
SRI J. D' CRUZ	Municipal Corporation of Delhi
SRI S. A. SWAMY (<i>Alternate</i>)	
SRI S. G. DEOLALIKAR	In personal capacity (403, Savitri Cinema Commercial Complex, Greater Kailash II, New Delhi)
SRI S. K. DHORI	Delhi Fire Service, New Delhi
SRI R. K. BHARDWAJ (<i>Alternate</i>)	
SRI DEVENDRA SINGH	In personal capacity (16 A, Maya Mahal, 17th Road, Khar, Bombay)
HYDRAULIC ENGINEER	Municipal Corporation of Greater Bombay, Bombay
CHIEF ENGINEER (SEWERAGE) (<i>Alternate</i>)	
SRI R. A. KHANNA	Public Health Engineering Department, Government of Madhya Pradesh, Bhopal
SRI D. K. MITRA (<i>Alternate</i> I)	
SRI I. S. BAWEJA (<i>Alternate</i> II)	
SRI S. T. KHARE	Public Health Engineering Department, Government of Maharashtra, Bombay
SRI A. S. KULKARNI	Municipal Corporation of Greater Bombay (Bombay Fire Brigade), Bombay
SRI V. B. NIKAM (<i>Alternate</i>)	
DR R. P. MATHUR	University of Roorkee, Roorkee
SRI C. L. TOSHNIWAL (<i>Alternate</i>)	
SRI K. GOVINDA MENON	Tamil Nadu Water Supply & Drainage Board, Madras
SRI T. G. SRINIVASAN (<i>Alternate</i>)	
SRI V. A. MHAIBALKAR	National Environmental Engineering Research Institute (CSIR), Nagpur
SRI C. V. CHALPATIRAO (<i>Alternate</i>)	
SRI K. GOVINDAN NAIR	Public Health Engineering Department, Government of Kerala, Trivandrum
SRI N. S. BHAIKAVAN (<i>Alternate</i>)	
SRI P. K. NAGARKAR	Maharashtra Engineering Research Institute, Nasik
SRI J. N. KARDILE (<i>Alternate</i>)	
PROF. Y. N. RAMACHANDRA RAO	Engineer-in-Chief's Branch (Ministry of Defence), New Delhi
MAJ B. S. PARMAR (<i>Alternate</i>)	
SRI O. P. RATRA	National Buildings Organization, New Delhi
SRI S. K. SHARMA	Central Building Research Institute (CSIR), Roorkee

INTERNATIONAL SYSTEM OF UNITS (SI UNITS)

Base Units

QUANTITY	UNIT	SYMBOL
Length	metre	m
Mass	kilogram	kg
Time	second	s
Electric current	ampere	A
Thermodynamic temperature	kelvin	K
Luminous intensity	candela	cd
Amount of substance	mole	mol

Supplementary Units

QUANTITY	UNIT	SYMBOL
Plane angle	radian	rad
Solid angle	steradian	sr

Derived Units

QUANTITY	UNIT	SYMBOL	DEFINITION
Force	newton	N	1 N = 1 kg.m/s ²
Energy	joule	J	1 J = 1 N.m
Power	watt	W	1 W = 1 J/s
Flux	weber	Wb	1 Wb = 1 V.s
Flux density	tesla	T	1 T = 1 Wb/m ²
Frequency	hertz	Hz	1 Hz = 1 c/s (s ⁻¹)
Electric conductance	siemens	S	1 S = 1 A/V
Electromotive force	volt	V	1 V = 1 W/A
Pressure, stress,	pascal	Pa	1 Pa = 1 N/m ²

BUREAU OF INDIAN STANDARDS

Headquarters:

Manak Bhavan, 9 Bahadur Shah Zafar Marg, NEW DELHI 110002

Telephones : 331 01 31, 331 13 75

Telegrams : Manaksanstha
(Common to all offices)

Regional Offices:

	Telephones
Central : Manak Bhavan, 9 Bahadur Shah Zafar Marg, NEW DELHI-110002	[331 01 31 331 13 75
*Eastern : 1/14 C.I.T. Scheme VII M, V. I. P. Road, Maniktola, CALCUTTA 700054	36 24 99
Northern : SCO 445-446, Sector 35-C, CHANDIGARH 160036	[2 18 43 3 16 41
Southern : C. I. T. Campus, MADRAS 600113	{41 24 42 41 25 19 41 29 16
†Western : Manakalaya, E9 MIDC, Marol, Andheri (East), BOMBAY 400093	6 32 92 95

Branch Offices:

'Pushpak' Nurmohamed Shaikh Marg, Khanpur, AHMEDABAD 380001	[2 63 48 2 63 49
‡Peenya Industrial Area, 1st Stage, Bangalore Tumkur Road BANGALORE 560058	[38 49 55 38 49 56
Gangotri Complex, 5th Floor, Bhadbhada Road, T. T. Nagar, BHOPAL 462003	6 67 16
Plot No. 82/83, Lewis Road, BHUBANESHWAR 751002	5 36 27
53/5, Ward No. 29, R. G. Barua Road, 5th Byelane, GUWAHATI 781003	3 31 77
5-8-56C L. N. Gupta Marg (Nampally Station Road), HYDERABAD 500001	23 10 83
R14 Yudhister Marg, C Scheme, JAIPUR 302005	[6 34 71 6 98 32
117/418 B Sarvodaya Nagar, KANPUR 208005	[21 68 76 21 82 92
Patliputra Industrial Estate, PATNA 800013	6 23 05
T.C. No. 14/1421, University P.O., Palayam TRIVANDRUM 695035	[6 21 04 6 21 17

Inspection Office (With Sale Point) :

Pushpanjali, 1st Floor, 205-A West High Court Road, Shankar Nagar Square, NAGPUR 440010	2 51 71
Institution of Engineers (India) Building, 1332 Shivaji Nagar, PUNE 411005	5 24 35

*Sales Office in Calcutta is at 5 Chowringhee Approach, P.O. Princep Street, Calcutta 700072 27 68 00

†Sales Office in Bombay is at Novelty Chambers, Grant Road, Bombay 400007 89 65 28

‡Sales Office in Bangalore is at Unity Building, Narasimharaja Square, Bangalore 560002 22 36 71